



STUDENT MANUAL

HEAVY EQUIPMENT & RIGGING SPECIALIST TRAINING

MODULE 2

UNIT 2: CALCULATING WEIGHTS & CENTER OF GRAVITY

Unit Objective

Upon completion of this unit, you will be able to better determine the Weights and Center of Gravity of steel, concrete and other objects

Enabling Objectives

You will:

- Review the Unit Weights (lbs per cubic foot) of materials to be found in many types of structures;
- Discuss three methods for calculating the weight of objects that may need to be lifted in US&R;
 - Volume x Unit Weight.
 - Area Method for concrete slabs and steel plates and shapes.
 - Weight per Foot method for complicated objects.
- Demonstrate methods for calculating the weights of Non-uniformly Shaped Objects;
- Discuss and practice simple Graphical Method for estimating the Center of Gravity of complicated and/or irregular shaped slabs;
- Review the rigorous, mathematic method for calculating the Center of Gravity





I. Calculating Weight of Objects to be Lifted

In order to safely move large objects using cranes and other heavy equipment, we must first, accurately calculate their weight. In the FEMA US&R System, the Structures Specialist (StS) will be most proficient in performing this task, but may not always be available. Therefore it is important that the HERS to be able to determine the weight of simple objects

Unit Weights of Common Building Materials

There are many references that give the unit weights of common building materials, in pounds per cubic foot.(the weight of a block of material that measures 1 ft wide x 1 ft high x 1ft deep).

The most common are:

- Reinforced concrete = 150 pcf **
- Steel use 490 pcf (use 500)
- Earth use 100 pcf
- Wood use 40 pcf (depending on species)

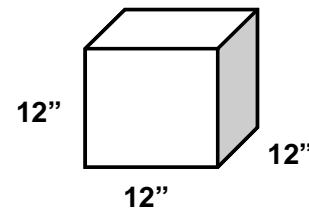

** = This assumes that the concrete weighs 145 pcf and the reinforcing steel adds 5 pcf. However, Concrete Beams and Columns are often more heavily reinforced. They may weigh as much as 175 pcf. This can be very important to know when lifting with a Crane. The weights of these, heavily reinforced members should be calculated by US&R Structures Specialists

Calculating the Weight of Simple Objects – Volume x Unit Weight

Simple concrete slabs, beams, and columns can easily be calculated by multiplying the Volume (Normally Height x Width x Length, in Feet) times the Unit Weight in Lbs per Cubic Foot

- For Simple, Solid Rectangular Solids, Wt = Height x Width x Length x Unit Weight

Example 1

$$2' \times 4' \times 20' = 160\text{cu-ft} \times 150\text{pcf} = 24,000 \text{ lbs.}$$

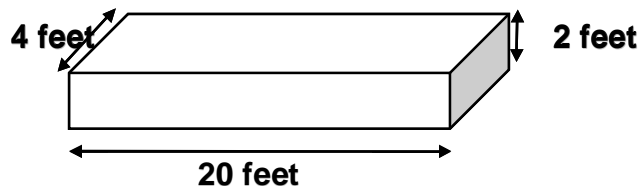

- For a Simple Rectangle with a Hole, one may simply subtract the H x W x L of the Hole

Example 2

$$8''/12''(6' \times 16' - 2.5' \times 2.5') \times 150\text{pcf} \\ 60\text{cu-ft} \times 150\text{pcf} = 8975\text{lbs}$$

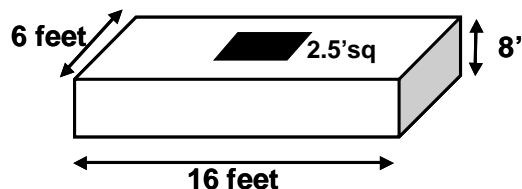



- For a Simple Solid Cylinder, like a Round Concrete Column, $Wt = 0.8 \text{ Diameter} \times \text{Diameter} \times \text{Length} \times \text{Unit Weight}$.

Example 3 **0.8 x Diameter x Dia x Length x Weight**
0.8 X 3' x 3' x 20' x 150pcf
144cu-ft x 150pcf = 21,600 lbs.

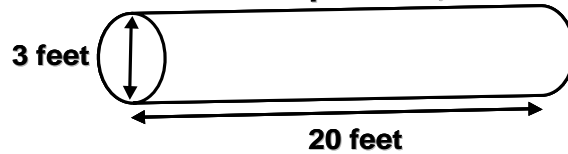

- For a Hollow Round Object, like a Pipe, we can use Method 1 - find the weight of the solid round, then subtract the weight of the hole

Example 4 **0.8 (4'x 4' - 3'x 3') x 20'x 150pcf**
112 cu-ft x 150pcf = 16,800 lbs.

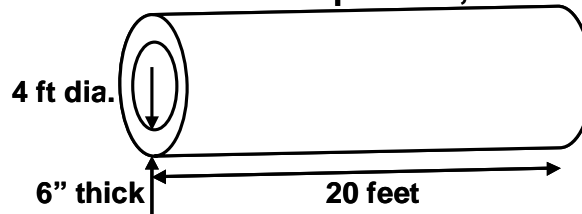

- For a Hollow Round Object, like a Pipe, we can also use Method 2 - find the weight of the unfolded slabs. The circumference x thickness x thickness x length x wt per cubic ft.
- The circumference of any circle is the constant, phi (3.14) times the diameter. To simplify, with only a small error we can use 3 times the diameter.
- One can also measure the distance around the pipe with a tape. This can be visualized as cutting the pipe lengthwise and unfolding it as illustrated here:

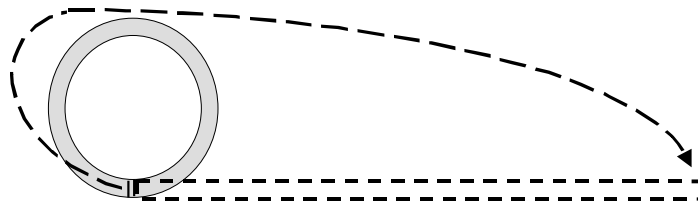

Example 5 **3 x 4' x 0.5' x 20' x 150pcf = 18,000 lbs.**
(7% higher – the thicker the greater error)

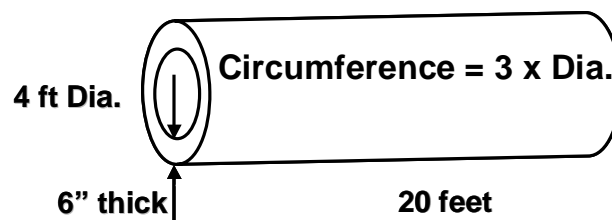



Calculating the Weight of Concrete Slabs – Using Area Method

The weights of concrete slabs may be more rapidly calculated by remembering the weight per square foot of various thickness slabs. If normal reinforced concrete weighs 150 pcf, then a 12” slab will weigh 150 psf. It also follows that:

- 10” slab weighs 125psf
- 8” = 100psf, 6” = 75psf, 4” = 50psf, and so on.

Re-do Example 1

4' x 20' 300psf = 24,000 lbs. (24” slab = 300psf)

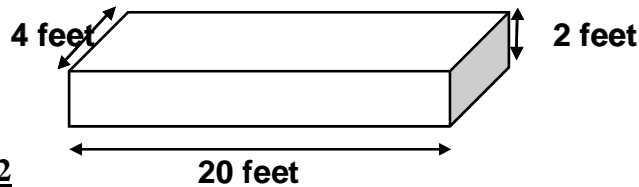

Re-do Example 2

6' x 16' 100psf = 8,975 lbs.

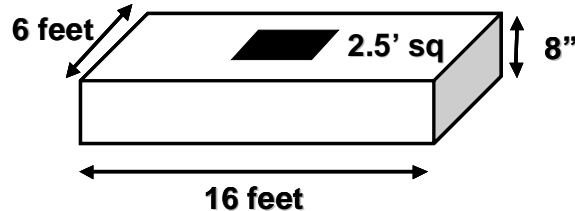

Calculating the Weight of complicated Objects – Using Weight per Foot Method

There is a very simple way to calculate the weight per foot of any steel, aluminum, concrete or wood cross-section when one starts with knowing the weight of a one-square-inch bar the material that is one foot long.

The weight of a one inch square (one square inch) bar that is one foot long is calculated by dividing the area of one side of the 1 ft x 1ft x 1ft Block used in the Unit Weight Method by 144 (the number of square inches in a square foot) as follows

- Reinforced concrete = 150 pcf /144 = 1.04 Use 1.0 (use 1.1 for Cols & Beams since there is more rebar)
- Steel use 490 pcf /144 = 3.4
- Wire Rope use 0.7 x 3.4 = 2.4 (since wire rope is not solid steel)
- Wood use 40 pcf /144 = .28

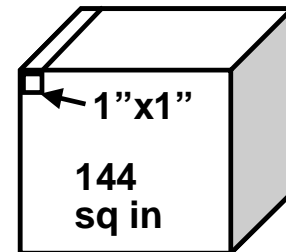

Using this information, the weight of any complicated shape can be calculated by multiplying this special unit weight (lbs per sq inch, per foot of length) times the Area of the cross section (in square inches) times the Length (in feet).

See the examples on the following page:



Calculating the Weight of Objects – Using Weight per Foot Method - Examples

- For Precast Concrete Double T (Single T and any long uniform shape would be similar

Example C1 **(2" x 96" + 5" avg. x 30" x 2) x 1.0 (PC Conc)**
(192 sq-in + 300 sq-in) x 1.0 = 492 plf
For 60ft long = 492 plf x 60ft = 29,520 lbs

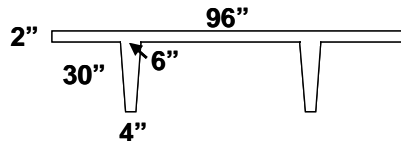

- For Steel Pl, Bar and Column Section

Example S1 **1" x 12" steel plate = 1" x 12" x 3.4 x 1 ft long = 40.8 lbs**

Example S2 **1 ½" Round Bar x 20 ft long = 1.5 x 1.5 x 0.8 (round) x 3.4 x 20 ft**
= 1.77 sq in x 3.4 x 20 ft = 120 lbs

Example S3 **Steel Column** **(2 x 36" x 2" + 2 x 12" x 2") x 3.4 x 36'**
(144 sq in + 48 sq in = 192 sq in) x 3.4 = 653 lbs per ft
653 plf x 36' = 23,500 lbs = 12Tons

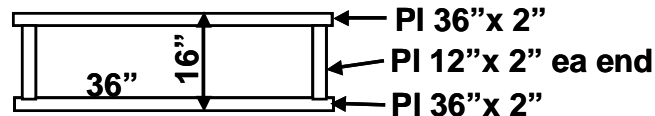

Calculating the Weight of Steel Plates and Shapes – Using Area Method

A one-inch thick steel plate weighs about 40 pounds per square foot (psf). Using this knowledge, we can quickly calculate the weight of most steel sections, by multiplying the actual thickness times 40 psf times the area of each plate that makes up the cross section.

- If a 1" plate = 40psf, then ¾" = 30psf, ½" = 20psf, ¼" = 10psf, and so on.

Re-do Example S3 Steel Column by Area Method

- 2" Steel = 2 x 40psf = 80psf
- Area of this section per foot of length = 2 x 3 sq ft + 2 x 1 sq ft = 8 sq ft
- Weight per foot = 8 sq ft x 80 psf = 640 plf
- Total weight = 640 plf x 36 ft long = 23,040 (about 2% less than in Example S3)

Example S4 Steel Pipe by Area Method

- If we have a steel pipe that is 12 inches in diameter, ½ inch thick and 16 feet long, and we remember that the circumference is about 3 times the diameter, the weight may be quickly calculated as follows:
 - 1/2" Steel = 1/2 x 40psf = 20psf: Area per foot = 3 x 1 = 3 sq ft
 - Weight per foot = 3 sf x 20psf = 60 plf, Total = 60 x 16 = 960 lbs
 - Exact Weight per foot = 61.4 plf (only 2% off)



Calculating the Weight of Non-uniformly Shaped Objects

In some cases it may be necessary to lift objects that vary in cross-section with in their length or are not rectangular. These objects may have varying thickness or diameter, or may have non-rectangular shapes. We will present a few examples of how to determine the weight of these.

- Tapered Wood Poles (or Concrete Piles)

In this case the Average Diameter may be used with the Weight per Foot Method as shown for this 20 ft long Wood Pole that has a 6 inch diameter tip and 12 inch dia, butt

Example W1

$$0.8(12 \times 12 + 6 \times 6) / 2 \times .28 \times 20 \text{ ft} = \text{Weight}$$

$$0.8 \times 90 \text{ sq in} \times .28 \times 20 \text{ ft} = 403 \text{ Lbs}$$

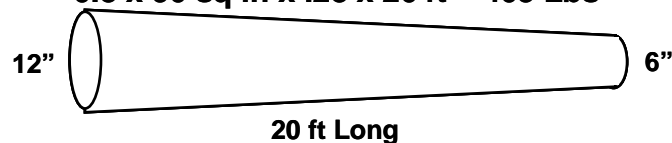

- L or Odd Shaped Slab of Uniform Thickness

In this case it is best to, first divide the Slab into Rectangles, then find the Total Volume, and lastly to multiply by the Unit Weight. See the Example C3

Example C2

$$8''/12'' (10' \times 6' + 6' \times 7') \times 150 \text{ pcf} = \text{Weight}$$

$$8/12 (102 \text{ sq-ft}) \times 150 \text{ pcf} = 68 \text{ cu-ft} \times 150 = 10,200 \text{ lbs}$$

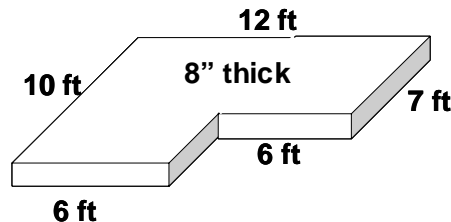

- Tapered Concrete Slab

In this case it is best to, first divide the Slab into a uniform thickness section and a triangular thickness section. Then, find the Total Volume, and multiply by the Unit Weight. Remember that the Area of a Triangle is Length x Width divided by 2

Example C3

$$(8''/12'' \times 4' \times 7' + 10''/12'' \times 4'/2 \times 7') \times 150 \text{ pcf} = \text{Wt}$$

$$(18.67 \text{ cu-ft} + 11.67 \text{ cu-ft}) \times 150 \text{ pcf} = 4,550 \text{ lbs}$$

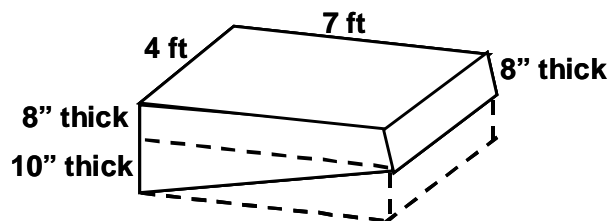



II. Center of Gravity

In order to maintain control when lifting objects, one needs to understand how suspended objects behave and how to locate the Center of Gravity (CG). To review, an object's CG is the point around which the object's mass is evenly distributed (that is, the object's three-dimensional balance point). When an object is suspended, it will rotate until its CG is located directly below the lifting point.

To properly control a lift, the rigging needs to be configured and connected in such a way that the lifting hook is as close as possible to a point directly over an object's CG.

In addition, to maintain stability during the lift, the connecting points should be placed above the CG. This is most important when lifting long objects (like columns, piles, and pipes) in the vertical position when using a single sling.

One should also use tag lines to control the horizontal rotation of a suspended object.

The CG of most objects to be lifted at US&R incidents is relatively easy to determine since the objects have rectangular shapes such as beams, columns, slabs, etc. The CG is at the Center or Mid-length of these Uniformly shaped Objects. We need methods to determine the CG of Odd Shaped Objects (mostly Concrete) and Tapered Sections.

We will discuss an easy, **Graphical Method** for finding Cg. of Uniform Thickness Slabs, developed by the Crosby Group, and the **Mathematical Method** that is familiar to engineers

However, first we need to review the **Properties of Right Triangles**. (Right Triangles are ones with 2 sides that make a 90 degree angle with each other)

We have stated that the Area of a Right Triangle is Length x Width divided by 2. The CG of a Right Triangle is found by measuring a distance one-third the height up from the base and a distance one third the width from the vertical side as shown

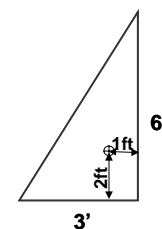
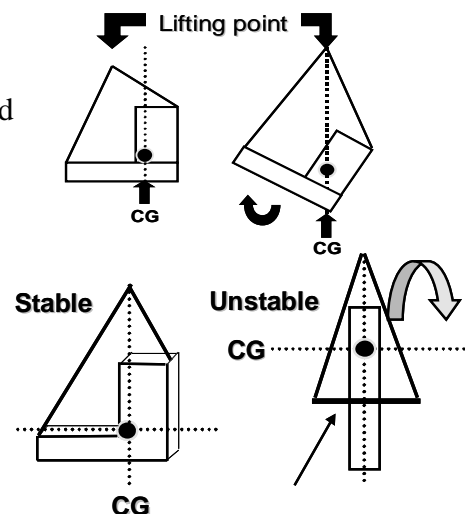

Graphical Method for finding Cg. of Uniform Thickness Slabs

This method was developed by the Crosby Group, and may be used to find the CG of uniform thickness slabs that are essentially a group of rectangles.

First, the weight of each rectangle is calculated, and the CG is marked at the center

Second, a straight line is drawn between the CG of two adjacent slabs.

Third the CG of this pair of slabs is calculated as a distance along this line that is proportional to the weight of each compared to the weight of the sum of the two

This group of two is then paired with an adjacent remaining rectangle until all the rectangles in the group have been considered. See Example on next page



Example of Crosby Method

Step One

Divide the Slab into a group of Rectangles and determine the weight & CG. of each

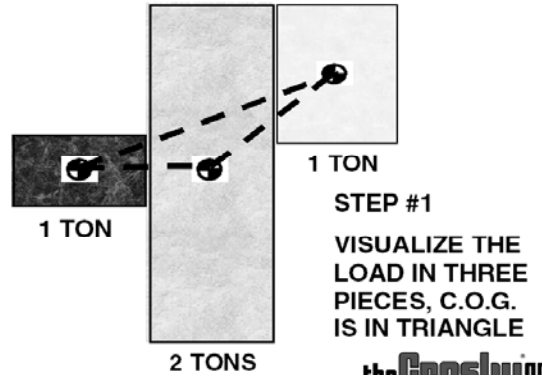

Step Two

Find the CG. of any two rectangles by drawing the line between the individual CGs, and determining the proportion of weight of the heaviest one to the total weight. The CG. is located on the Line, the same proportional of the total line length, measured from the CG. of the smaller rectangle

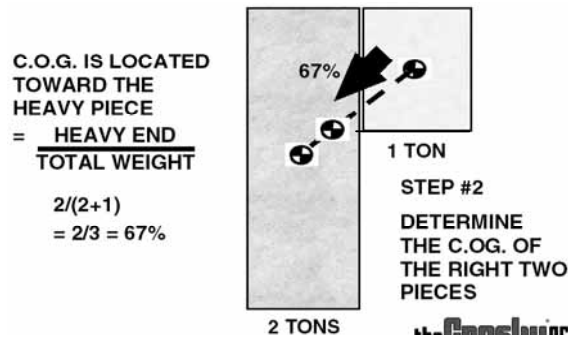

Step Three

Find the CG. of the three rectangles by drawing the line between the CG. of the pair that you just determined and the remaining rectangle. Find the proportion of the first two slabs (heavy end) to the weight of all three slabs. Again, the CG. is located on the Line, the same proportional of the total line length, measured from the CG. of the smaller rectangle

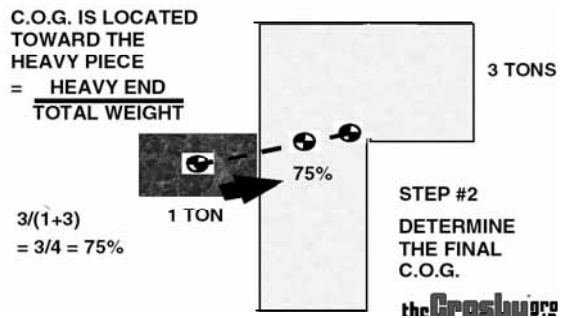

Example using a Rectangle and Triangle

One uses the same steps, but, in this case, the CG. of the triangle is at the Third Point, not the Center

C.G. is Located Toward Heavier Piece

$$\frac{\text{Heavy Piece}}{\text{Total Weight}} = \frac{1800}{2700} = \frac{2}{3}$$

⊕ = C.G. of each prism

⊗ = C.G. of group

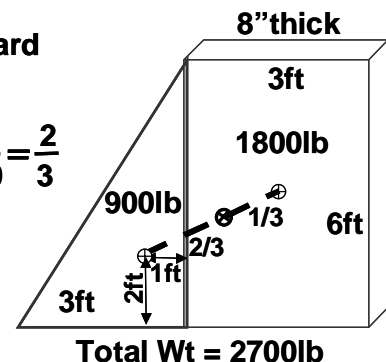



Mathematical Method for finding CG.

Calculate the CG of odd shaped objects, as follows:

- The CG of all rectangular, constant thickness objects is located at the intersection of the mid points of all three sides.
- The CG of a right triangular, constant thickness objects is located at the 1/3 point of the triangular shape and at mid-thickness.
- Most odd-shaped objects can be divided as a group of rectangular and right triangular shapes
- To determine the CG of a group, remember that the distance (in any direction) to the CG is the sum of the moments of mass (weight) divided by the total weight.

Examples

Center of Gravity Calculation

$$H = \frac{(2400 \times 2 + 1200 \times 6)}{3600} = 3.33$$

$$V = \frac{(2400 \times 3 + 1200 \times 1.5)}{3600} = 2.5$$

⊕ = CG of each prism
 ⊗ = CG of group

Total Wt = 3600lb

Center of Gravity Calculation

$$H = \frac{(1800 \times 1.5 + 900 \times 4)}{2700} = 2.33$$

$$V = \frac{(1800 \times 3 + 900 \times 2)}{2700} = 2.67$$

⊕ = CG of each prism
 ⊗ = CG of group

Total Wt = 2700lb



Calculate CG. of Slab with Hole

In US&R we often need to determine the weight and CG. of a slab with a hole in it. The weight is found by determining the total weight and subtracting the weight of what has been removed (Weight of the Hole).

The CG. is found by using the Mathematical Method, with the Hole being treated as a minus number.

Example

$$V = \frac{(4000 \times 4 - 900 \times 2.5)}{4000 - 900}$$

$$V = \frac{(16,000 - 2250)}{3100} = 4.44$$

⊕ = C.G. of each prism 3ft
⊗ = C.G. of group

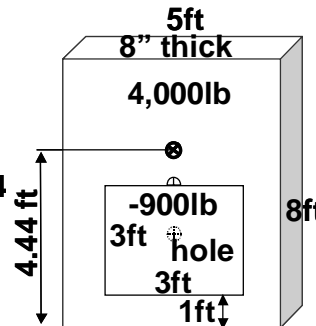

$$Wt = 4,000 - 900lb = 3,100$$

In this example the hole is centered on the slab, so that we know that the CG. remains along the center of the long axis of the slab. The method can be used, as well, if the hole was not centered, but there would be an additional calculation to find the CG in the side-to-side direction

III. Unit Summary

The HERS must be prepared to find the weight and CG. of objects that need to be lifted in emergency situations. Often the Structures Specialist will be available to help, but in many cases that help may not be immediately available.

It is important that the HERS becomes proficient in determining the weights of most simple objects. We have discussed the following methods

- Volume x Unit Weight Method to determine weight
- Weight per Foot Method to determine weight
- Area Method to determine the weight of steel sections

For finding the center of gravity of other than simple objects, the HERS can do the following

- Crosby Method for finding CG of non rectangular slabs.
- Mathematical Method for finding CG., but if the Structures Specialist is available, they should help the HERS with this calculation.

Whatever method is used, including a rough guess, it is always best, after rigging the object, to lift it slowly, just off the ground to see if it starts to rotate. If it rotates, that will indicate that the rigging must be shifted in order to properly “Capture” the CG.

